

# CLARK SYNTHESIS **TACTILE SOUND**<sup>®</sup>

## Installation Guide

- TST429-Platinum Transducer
- TST329-Gold Transducer
- TST239-Silver Transducer
- AW339-All Weather Transducer

For accessories and other helpful information, visit our  
web site

[www.clarksynthesis.com](http://www.clarksynthesis.com)

## Table of Contents

Important Product Information	2
Introduction	3
Supplied Parts	4
Installation: Overview	6
Installation: Chairs and Couches	8
Installation: Traditional Floors and Platforms	9
Installation: Laminated I-Beam Floors	10
Installation: Wood Decks	12
Wiring and Connections	14
Troubleshooting	18
Warranty and Returns	19

**full  
contact  
audio**<sup>™</sup>

**CAUTION:** THIS TRANSDUCER  
CONTAINS AN EXTREMELY POWERFUL  
MAGNET. DO NOT PLACE IN CLOSE  
PROXIMITY TO TUBE TV MONITORS, TUBE  
VIDEO MONITORS, AND MAGNETIC MEDIA.



# IMPORTANT PRODUCT INFORMATION

---

1. **DO NOT DROP THE TRANSDUCER-** The Transducer can be damaged both internally and externally if dropped. Damage caused by dropping the Transducer is not covered under the warranty.
2. **DO NOT EXPOSE THE TRANSDUCER TO HIGH DISTORTION LEVELS-** Exposing the Transducer to high levels of distortion may damage the unit. This type of damage is not covered under the warranty. If the Transducer stops playing, it is likely that the built-in protection circuit has activated. In the event this happens, turn the amplifier off for approximately 60 seconds to allow the circuit to reset. Turn down the volume on the input signal and amplifier. Operate the system at lower volume levels to avoid overloading the Transducer.
3. **USE CAUTION WHEN INSTALLING IN FURNITURE-** If using this Transducer on a chair, sofa, or couch, insure the Transducer is protected from hitting the floor and from entanglement with any recliner components. Severe damage may occur to the wiring. This type of damage is not covered under the warranty.
4. **CABLE PLACEMENT-** Use caution when running the cable from the amplifier to the Transducer. Do not lay the cable in high-traffic areas where tripping or entanglement may occur.
5. **DO NOT CARRY THE TRANSDUCER BY THE CABLE-** Never carry the Transducer by its cable. This can damage the strain relief and internal wiring of the Transducer. Damage of this type will not be covered under the warranty.
6. **DO NOT REMOVE THE STRAIN RELIEF-** Removing or altering the strain relief fitting connecting the wire to the thumper may permanently damage the Transducer. This fitting is carefully installed at the factory. Any alteration or adjustment of this fitting will void the warranty.
7. **AVOID EXCESSIVE HEAT-** Exposure to excessive heat will result in internal temperatures that can cause damage to the components. Damage caused by neglect will not be covered under warranty.
8. **STORAGE-** Insure the components are adequately protected when storing or transporting.
9. **USE PROPER AMPLIFICATION-** Insure the Transducer is being powered by an amplifier that is stable at 4 ohms and delivers at least 100 to 150 watts into 4 ohms per Transducer.
10. **EXTERNAL VOLUME CONTROLS-** Do not use with external volume controls rated at less than 100 watts.

**Before you drill holes and run wires, take a few moments to review this Installation Guide. Then plan out the steps you'll need to take for your particular application. This will save you time in the end and reduce the possibility of errors and/or damage to the Transducer.**

Thank you for purchasing a Clark Synthesis Tactile Sound® Transducer, and welcome to the amazing world of Tactile Sound!

Since 1994, Clark Synthesis has been giving its customers the ability to experience sound in a completely different way. As you know, most of the sound we hear reaches our ears via airborne vibrations, like those produced by loudspeakers. However, there are four additional pathways through which we perceive acoustic energy, all of which fall into the category of tactile sound. These additional pathways include:

- Deep tissue and muscle mass
- Skeletal Joints
- Skin Sensation
- Bone Conduction

To capitalize on these additional means by which we perceive acoustic energy, Tactile Sound Transducers have been designed to send high-quality audio to the listener by producing vibrations over a full range of tactile and audible frequencies. When attached to a resonant surface, the Transducers supplement ordinary speakers and subwoofers, effectively increasing the proportion of tactile sound. Consequently, you feel the natural percussive impact of sounds, bringing life to sound effects like hard footsteps, door slams, plucked strings, drum beats, and explosive movie effects, all while enjoying greater clarity, depth, and realism.

Additionally, because Transducers increase the perceived “loudness” of the sound you are hearing, you are able to lower the volume on your system to a level that is both safer for your ears and less bothersome to neighbors.

Some of the most common applications for Tactile Sound Transducers include home theaters, listening rooms, outdoor decks, military simulators, theme park attractions, game chairs, professional music, and swimming pools.

In home theaters and listening rooms, our Transducers provide the user with a greater depth of experience when watching movies, listening to music, and playing video games.

For outdoor applications, our AW339 All Weather Transducers mount underneath decks, keeping the audio equipment out-of-sight while transferring audio to the surface of the deck.

Many military and flight simulator companies use our TST329 Gold Transducers to bring a greater sense of realism to training exercises.

Pool enthusiasts use our AQ339 Aquasonic™ underwater pool speakers to send full-range audio into the water, providing high-quality underwater music.

As you can see, the uses for our Transducers are many and the experience is amazing! We are glad you chose Clark Synthesis Transducers and we hope your listening experience takes you to new levels of acoustical enjoyment!

# Supplied Parts

## SUPPLIED PARTS (ILLUSTRATED BELOW)

- A. (1) TST209 Transducer
- B. (1) Unimount Bracket
- C. (1) 3/8"-16 x 3" Hanger Bolt
- D. (1) 3/8"-16 x 3" Threaded Stud
- E. (1) 3/8"-16 x 1.5" Threaded Stud
- F. (1) 3/8"-16 x 1" Hex Bolt
- G. (4) #12 x 1" Screw
- H. (2) 3/8" Jam Nut
- I. (4) #12 Washer
- J. (4) #12 Lock Washer
- K. (1) 3/8" Washer
- L. (1) 3/8" Lock Washer
- M. (1) T-Nut
- Installation Guide

## REQUIRED TOOLS AND MATERIALS

Depending on your application, you will need some or all of these tools and materials for your installation:

- #2 Phillips Screwdriver
- (2) 9/16" Open-Ended Wrenches
- Drill
- Saw
- Wire Stripper
- Soldering Gun or Wire Nuts
- Adhesive (construction glue)
- Hardwood (oak, maple, ash, etc., not pine or softwoods) for creating mounting bridges
- Speaker Cable (min. 16 AWG; 12-14 AWG recommended)

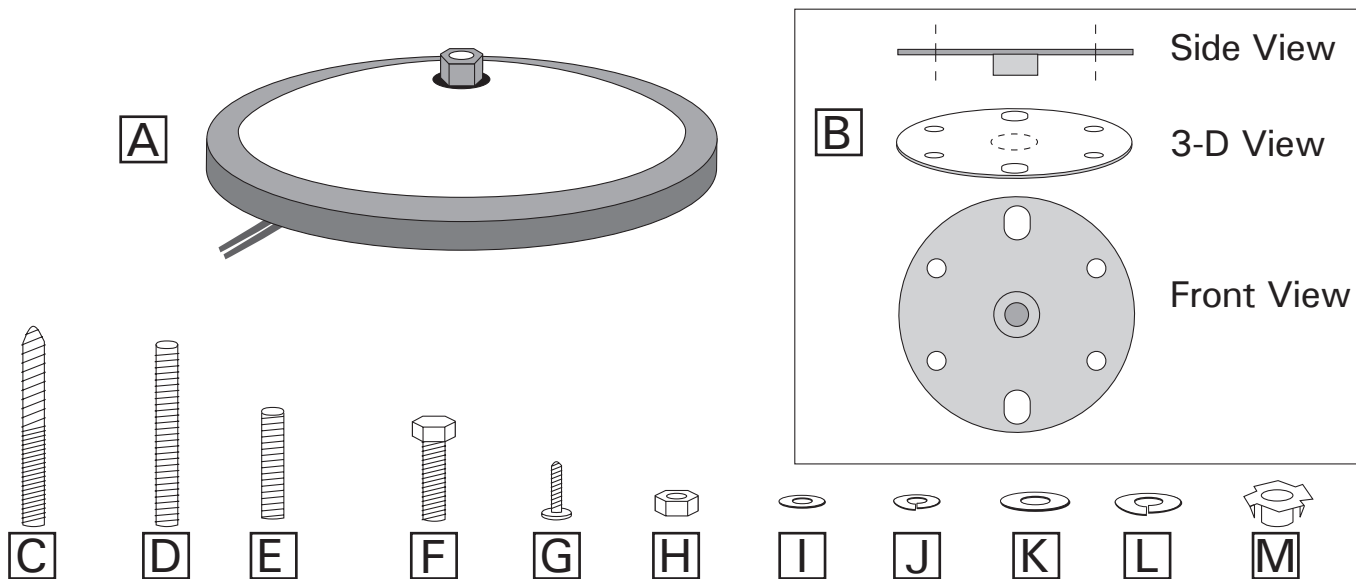

# General Information

One of the best materials for carrying tactile vibrations is wood. In most applications, the TST should be centrally located on the structure (chair, floor, riser, deck, etc.) in order to evenly distribute the tactile effect. When two or more TSTs are used on one structure, they should be spaced equidistant from each other and the edges/boundaries of the structure. Mounting to a bridge, joist, or frame member is preferred.

## General Location Diagram

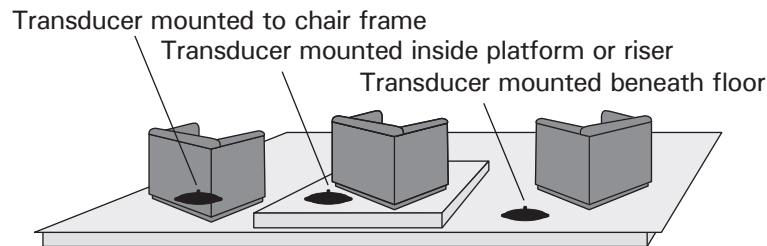

NOTE: The TST329 and AW339 Transducers are designed to be mounted in any orientation. The TST239 and TST429 transducers are designed to be mounted in a horizontal orientation ONLY.

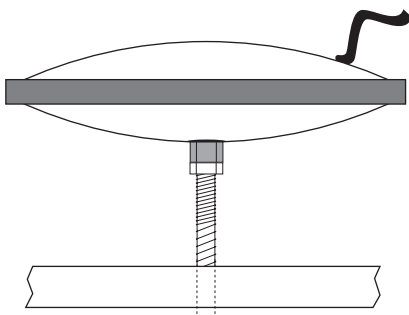

**Correct for all  
Transducers**

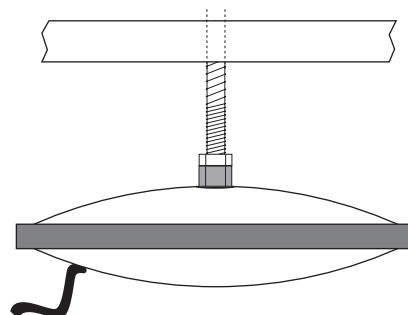

**Correct for all  
Transducers**

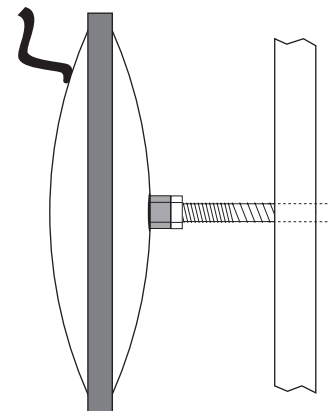

**Correct for TST329 and  
AW339 Transducers ONLY**

# Installation: Overview

## Installation Type: Unimount Bracket

Screws into the bottom of the mounting surface.  
Requires access only to the bottom of the mounting surface. Requires a flat or nearly flat mounting surface.

**Minimum 4-1/2" vertical space required, including 1/2" clearance between the Transducer and the floor.**

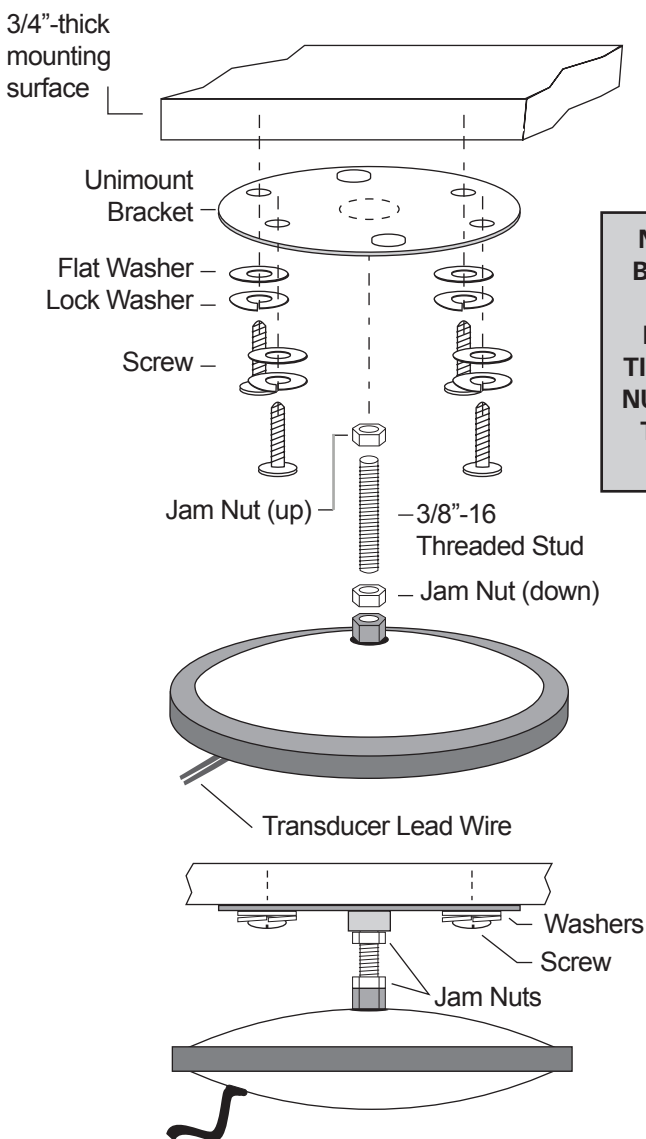

**NEVER TIGHTEN BY TURNING THE TRANSDUCER. MAKE SURE TO TIGHTEN THE JAM NUT AGAINST THE TRANSDUCER'S BRASS NUT**

## Installation Type: Hanger Bolt

Screws into the bottom of the mounting surface (into a 5/16" drilled hole). Requires access only to the bottom of the mounting surface.

**Minimum 3-1/2" vertical space required, including 1/2" clearance between the Transducer and the floor.**

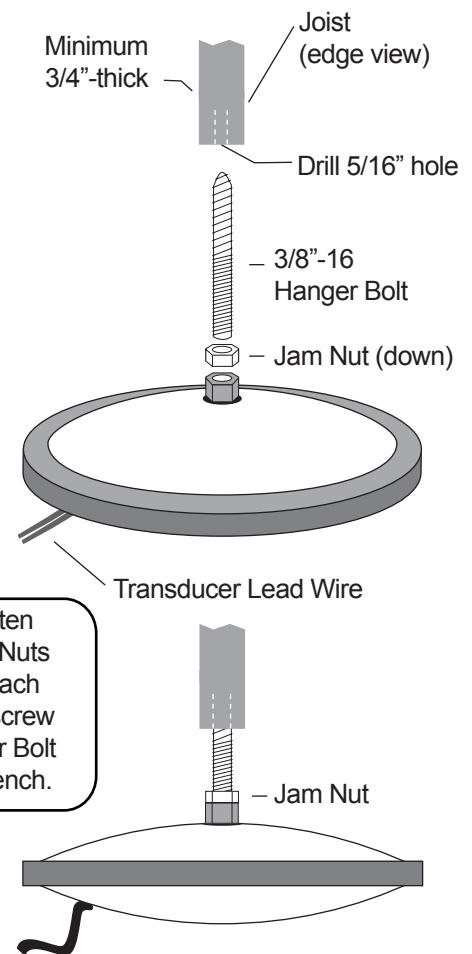

# Installation: Overview

## Installation Type: T-Nut

Requires initial access to the top of the material to insert the T-Nut, which installs flush to the surface. (Drill a 7/16" hole for the T-Nut.)

**Minimum 3-1/2" vertical space required, including 1/2" clearance between the Transducer and the floor.**

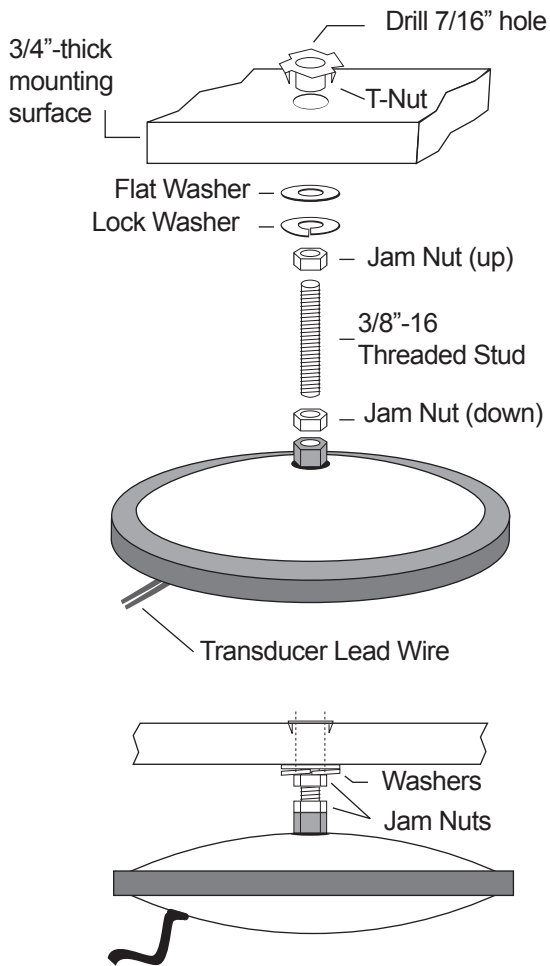

**NEVER TIGHTEN BY TURNING THE TRANSDUCER. MAKE SURE TO TIGHTEN THE JAM NUT AGAINST THE TRANSDUCER'S BRASS NUT**

## Installation Type: Hex Bolt

For use with metal or other high-tensile mounting surfaces no thicker than 1/4". Requires access to the top of the mounting surface both to install the bolt and to tighten it.

**Minimum 3-1/4" vertical space required, including 1/2" clearance between the Transducer and the floor.**

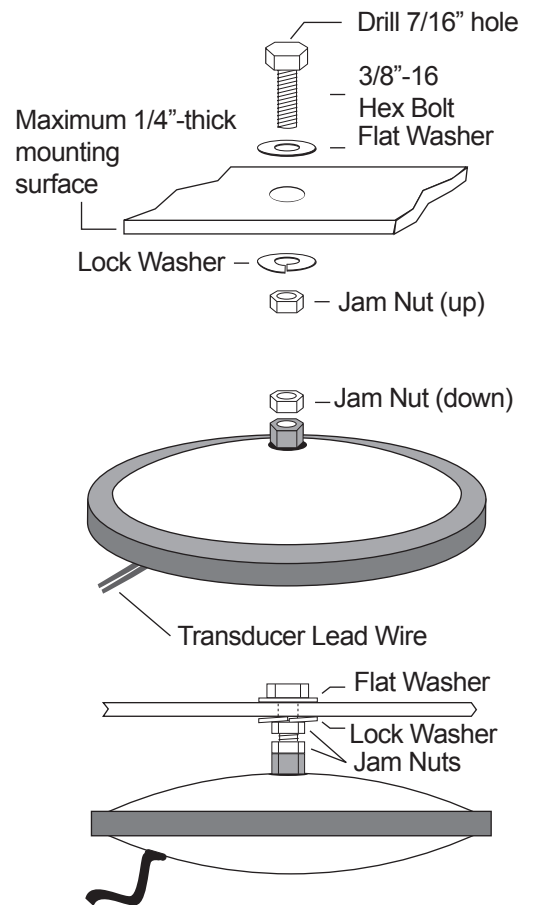

# Installation: Chairs & Couches

As a general rule, most chairs and couches have an underlying wooden frame. The Transducer can be mounted directly to a frame member or to a hardwood bridge that is rigidly secured to chair or couch's bottom frame. The bridge should be at least 3/4" thick and cut to span the two frame members or connect two sides of a box frame. The more centrally located the frame member or bridge is on the overall structure, the better the distribution of tactile sound.

For best results, the Transducer should be parallel to the ground (horizontal) so that the motion is up and down as opposed to sideways. The Transducer can be mounted to either the top or bottom of the bridge. When attaching the Transducer to the top of the bridge, be sure that the Transducer and the wiring does not interfere with any recliner mechanism. When attaching the Transducer to the bottom of the bridge, be sure that the Transducer does not touch the floor.

A chair or couch with armrests is preferred since a significant amount of tactile sensation is felt in the hands and arms.

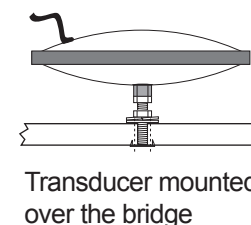
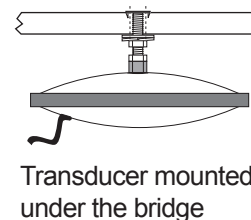
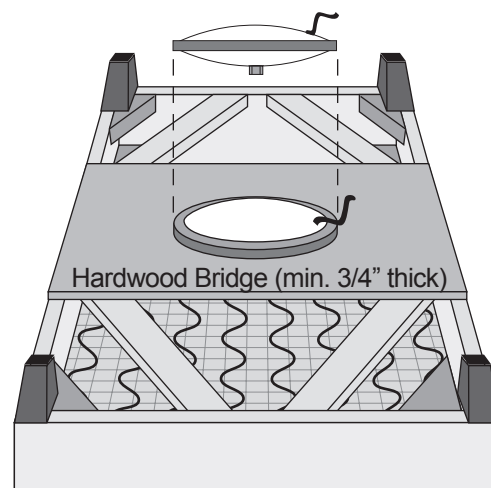



# Installation: Traditional Floors & Platforms

## TRADITIONAL FLOORS

Transducers may be mounted under a floor by attaching a hardwood bridge between adjacent floor joists, or by installing a 2" x 6" bridge with a curved niche. When installing under a floor, access may be from the basement or the ceiling below the floor. The TST will be mounted to a bridge connected between adjacent floor joists.

If your goal is to excite the area of the floor directly beneath a chair, then attach the Transducer to the closest joist underneath the chair.

Note: Carpeting and padding may reduce the tactile effect.

## PLATFORMS

Recommendation: Clark Synthesis recommends using only TST429 Platinum Transducers for platforms. Use of (1) TST429 Platinum Transducer for every 4 ft. by 8 ft. area of the platform is suggested.

Platforms are a great alternative to mounting a Transducer directly to a chair. This method is especially practical in home theaters with multiple rows of seating placed on platforms. An activated platform will deliver tactile sensations to your feet as well as the rest of your body via the chair.

Whether constructing a new platform or fitting Transducers onto an existing one, it is best to space the Transducers an equal distance from each other and the edges of the platform. If using only one Transducer, locate the Transducer in the center of the platform. Be sure to leave a way to access the Transducer should service be required.

To minimize energy loss into the floor, use Isolation Feet between the platform and the floor. Do not glue a platform to a concrete floor.

Clark Synthesis recommends using plywood or hardwood for the platform's top surface. **DO NOT USE MDF (medium-density fiberboard)**. We highly recommend using adhesive and screws instead of nails. Loose fitting joints can cause unwanted vibrations and buzzing noises.

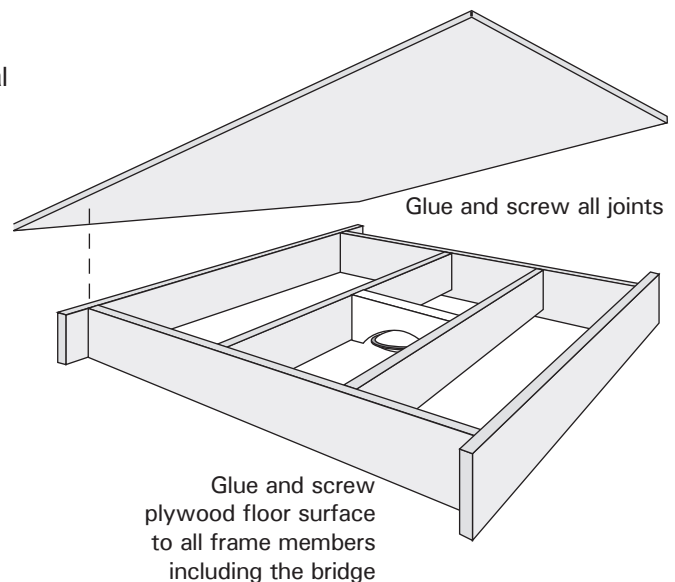
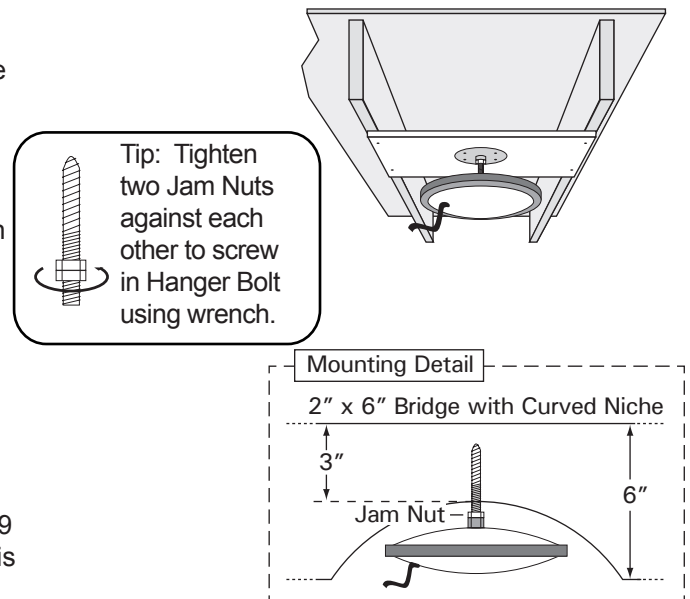

# Installation: Laminated I-Beam Floors

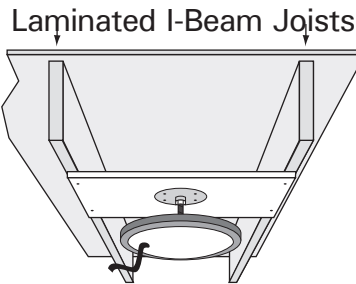

The Transducer mounts on 1"x 6" hardwood bridge spanning two joists, using the Unimount Bracket (shown) or the threaded stud with T-Nut. Attach the bridge to the bottom face of the joists using adhesive and screws.

## Installation using the Unimount Bracket

1. Attach a 1" by 6" hardwood bridge to the two I-beams using adhesive and screws.
2. Attach the Unimount Bracket to the bridge using machine screws with flat washers and lock washers.
3. Screw the a Threaded Stud into the threaded insert on the Unimount Bracket.
4. Spin the two Jam Nuts onto the stud. You will tighten them later.
5. Screw the Transducer onto the Stud until a slight resistance is felt (approx. 5 or 6 turns). When resistance is felt, stop turning. **DO NOT OVERTIGHTEN THE TRANSDUCER!**
6. Tighten one Jam Nut against the Unimount Bracket.
7. Tighten the other Jam Nut against the Transducer's brass nut using two 9/16" wrenches as follows: One wrench firmly grasping the Transducer's brass nut while the second tightens the Jam Nut against it. **NEVER TIGHTEN BY TURNING THE TRANSDUCER – MAKE SURE TO TIGHTEN THE JAM NUT AGAINST THE TRANSDUCER'S BRASS NUT.**
8. Use solder or wire nuts to connect speaker wire to the Transducer's wire leads.
9. Run the speaker wire to your audio system.
10. Connect the Transducer to your audio system (see "Wiring and Connections" in this guide).

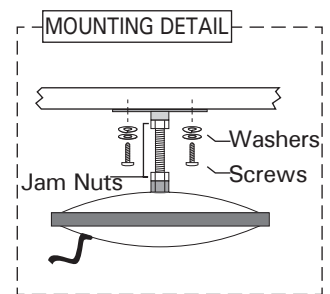

## Installation using the T-Nut

1. Drill a 7/16" hole in a 1" by 6" hardwood bridge. Press the T-nut into the hole on the side of the mounting surface opposite the Transducer.
1. Attach the hardwood bridge to the two I-beams using adhesive and screws.
2. Screw a Threaded Stud completely into the T-Nut.
3. Place the 3/8" flat washer and 3/8" lock washer on the Threaded Stud, then spin the two Jam Nuts onto the stud (flat washer against the mounting surface, lock washer between flat washer and jam nut). You will tighten the jam nuts later.
4. Screw the Transducer onto the Stud until slight resistance is felt (approx. 5 or 6 turns). When resistance is felt, stop turning. **DO NOT OVERTIGHTEN THE TRANSDUCER!**
5. Tighten one Jam Nut against the lock washer, flat washer, and mounting surface.
6. Follow steps 6 through 9 under "Steps for installation using the Unimount Bracket" (as shown above).

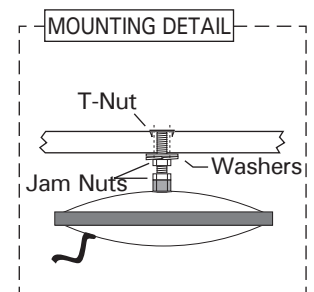

---

# Notes

# Installation: Wood Decks

- 1** Measure the overall dimensions of the deck. For best results, it is recommended that one (1) AW339 be installed for every 10 ft. by 10 ft. (3 m by 3 m) section of deck. For example, if you have a deck that is 10 ft. by 20 ft. (3 m by 6 m), you would need to install two (2) AW339 transducers on that deck.

The transducer should be mounted in a location that is equally spaced from the sides of the deck and other transducers. As general examples, the diagrams below provide top views of 10 ft. by 10 ft. (3 m by 3 m) and 10 ft. by 20 ft. (3 m by 6 m) deck surfaces with the transducers mounted equal distances from each other and from the edges of the deck.

If the deck is a custom shape, approximate the placement of the transducers using the general recommendation of one transducer for every 100 ft.<sup>2</sup> (9 m<sup>2</sup>).

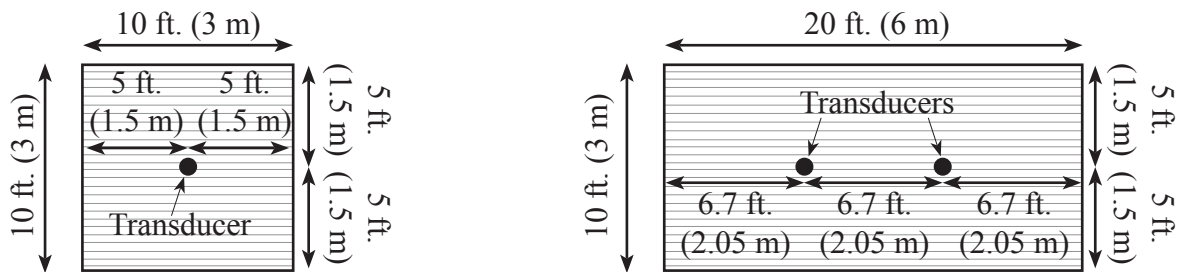

- 2** When determining the actual mounting location(s), it is important to decide which type of mounting style you want to use. There are two commonly used mounting styles: the joist mount or the bridge mount. See the diagrams of each style below.

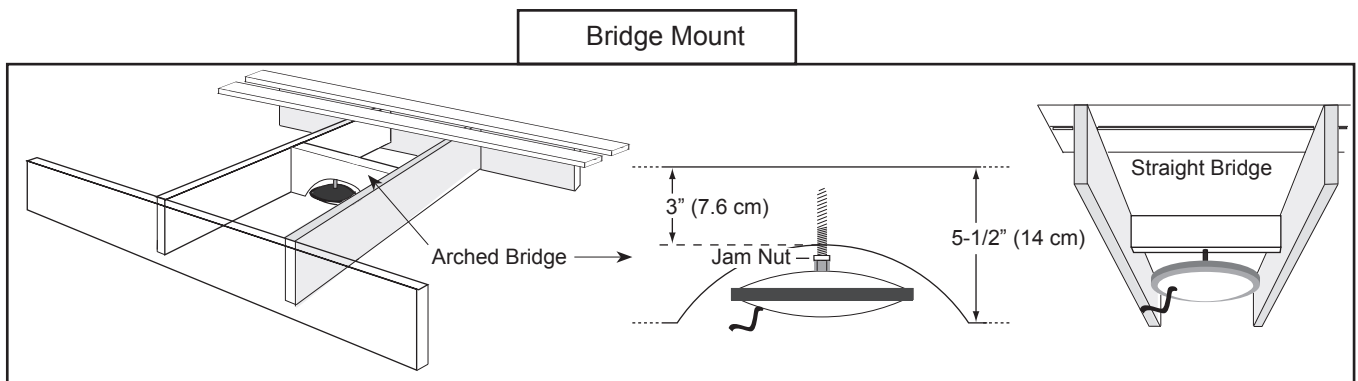
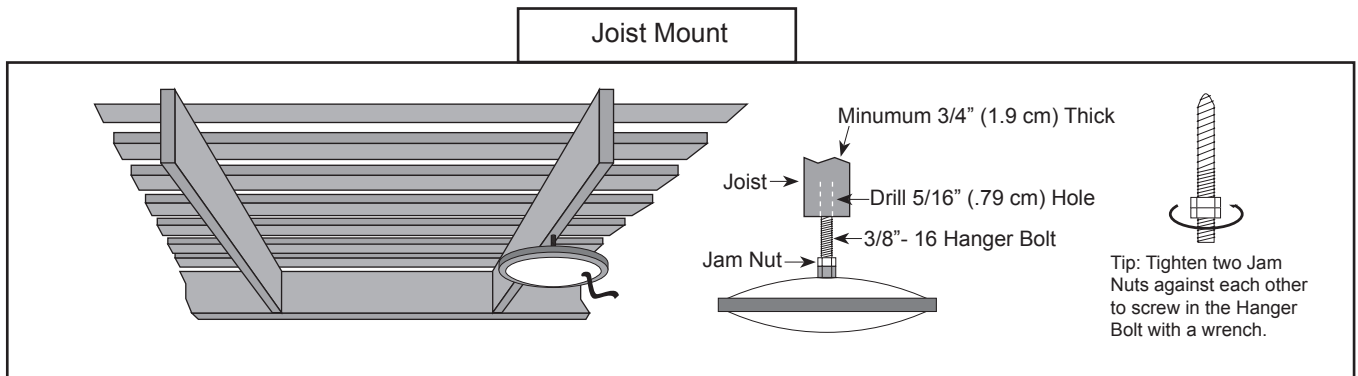

# Installation: Wood Decks

- 3 If you are using the joist mount, determine the general mounting location and then find the closest joist support for that location. Drill a 5/16" (.79 cm) pilot hole that is approximately 2 inches (5 cm) deep into the joist. Place two (2) Jam Nuts on the Hanger Bolt and tighten the nuts together (see the joist style diagram on the previous page). Turn the Hanger Bolt into the joist up to the place on the bolt where the threads change from wood threads to machine threads. Loosen and remove one of the Jam Nuts.

Lifting the transducer up to the Hanger Bolt, place the transducer's brass mounting nut onto the machine thread side of the Hanger Bolt. Insuring not to cross-thread the Hanger Bolt into the brass nut, gently turn the transducer 5 to 6 complete revolutions. If you feel resistance, stop immediately.

CAUTION: DO NOT OVERTIGHTEN.

Spin the Jam Nut that is still on the Hanger Bolt down to the brass nut and, using two wrenches (one on the Jam Nut and one on the brass nut), tighten the Jam Nut against the brass nut.

CAUTION: DO NOT TIGHTEN THE JAM NUT TO THE BRASS NUT BY TURNING THE TRANSDUCER. THIS WILL RESULT IN SEVERE DAMAGE TO THE TRANSDUCER AND WILL VOID THE WARRANTY.

- 4 If you are using the bridge mount, determine which type of bridge you want to use (straight or arched). If you are using the arched bridge style, cut the arch using the dimensions shown on the previous page.

Cut the length of the bridge board to fit snugly between the two support joists. The bridge board must be at least 3/4" (1.9 cm) thick. Screw the bridge board securely between the support joists. Follow the directions for installing the Hanger Bolt and the transducer under Step 3, above.

- 5 Once the transducer is mounted to the Hanger Bolt, run exterior grade speaker wire from your audio equipment (receiver and/or amplifier) to the wire lead on the transducer. Connect the wires, insuring the splice is as waterproof as possible. Your AW339 All-Weather transducer is now ready to enjoy.

# Wiring & Connections

## HOME THEATER

There are several different ways to hook up your system in terms of which source material (signal) is delivered to the amplifier(s) and Transducer(s). Since our inception, we have discovered that approximately half of our customers prefer using the LFE/SUB signal with their Transducers. The other half prefer using the Right Front (RF) and Left Front (LF) signals. Additionally, there are a few people who like to use multiple signals concurrently. In the following instructions, we provide you with general diagrams for each of these hookup methods.

### LFE/SUB Hookup

The LFE, SUB, or Subwoofer output is the signal that you send to the subwoofer.

If your receiver has only one LFE/SUB/Subwoofer output port, connect a “Y” adapter to that output. This will allow you to split the signal between the Transducer and the subwoofer. To do this properly, connect your subwoofer to one side of the “Y” adapter. Connect the amplifier to the other side of the “Y” adapter. To reduce the amount of noise produced when using this signal, use another “Y” adapter cable when connecting to the amplifier. This will allow you to connect the signal into both the Left and Right input connectors on the amplifier.

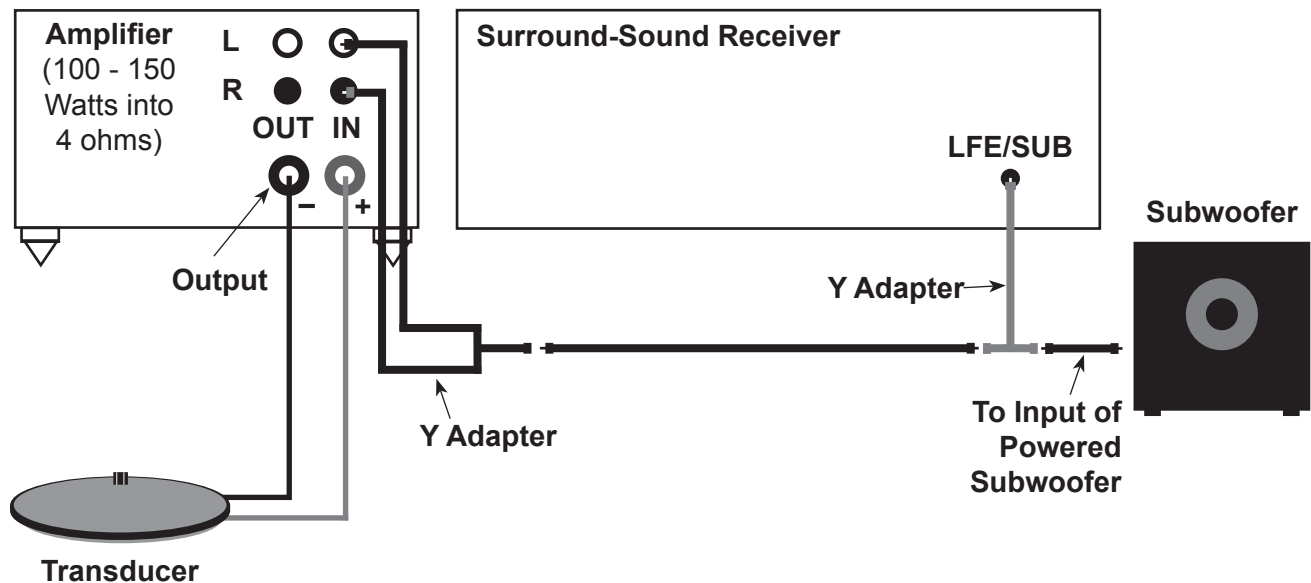

# Wiring & Connections

## Right Front (RF) and Left Front (LF) Hookup

For this hookup, connect the RF and LF Pre-Amp Outputs to the amplifier inputs.

**NOTE:** Not all receivers have Pre-Amp outputs for the Right Front and Left Front outputs. If you have a question about your receiver's outputs, please consult your owner's manual or contact your receiver's manufacturer.

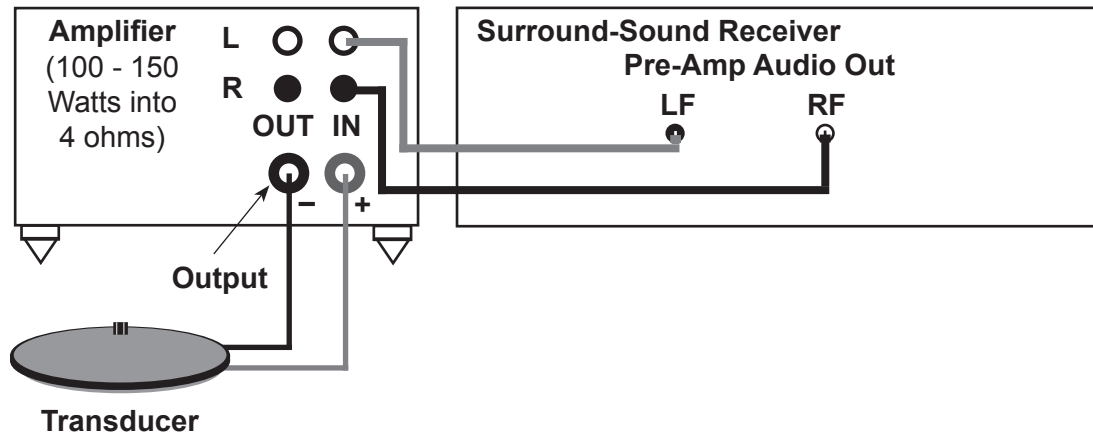

## Multiple Signal Hookup

This configuration is a little more complicated. You will need a small mixer to make this work. Connect the signals you want to use to the mixer input. Then, connect the mixer output to the amplifier input using a "Y" adapter.

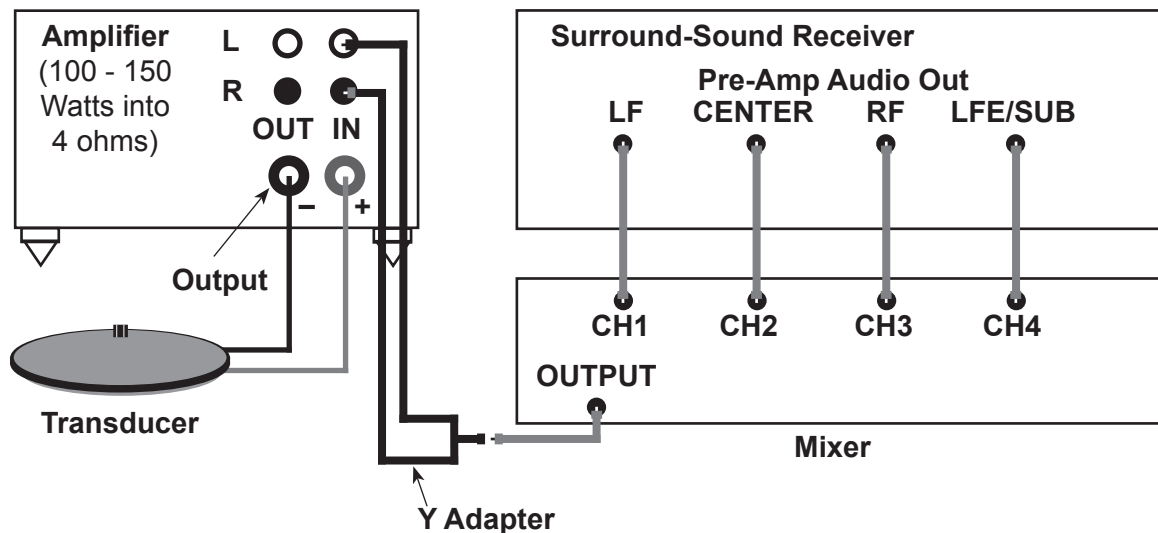

# Wiring & Connections

## Two Transducers with a Stereo Amplifier

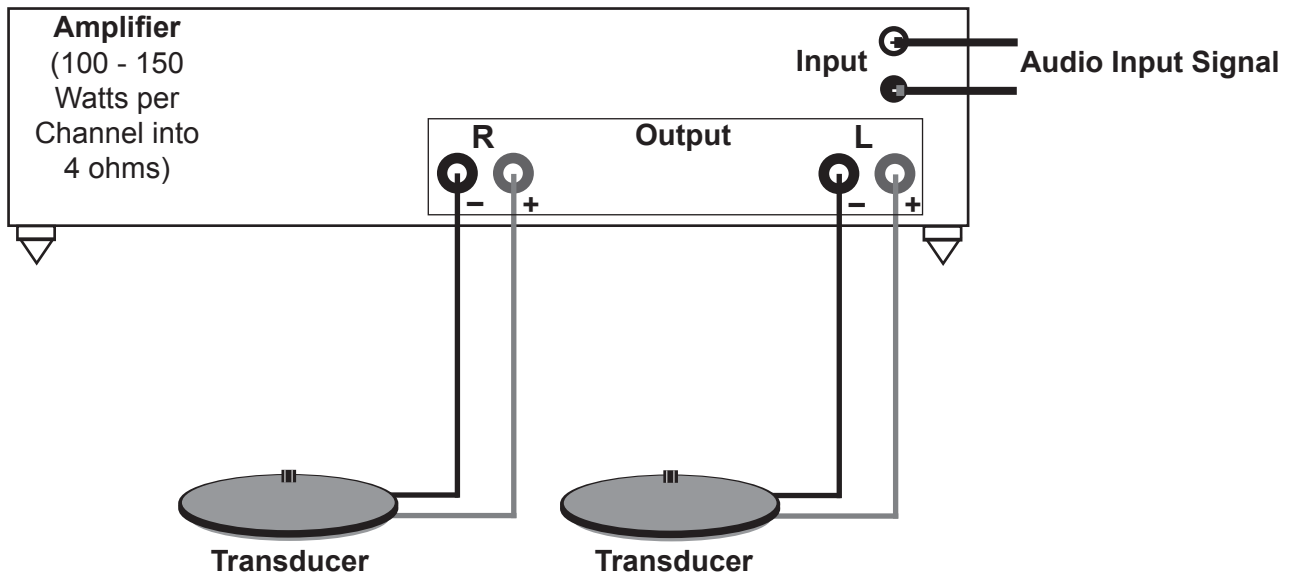

## Two Transducers with a Mono Amplifier

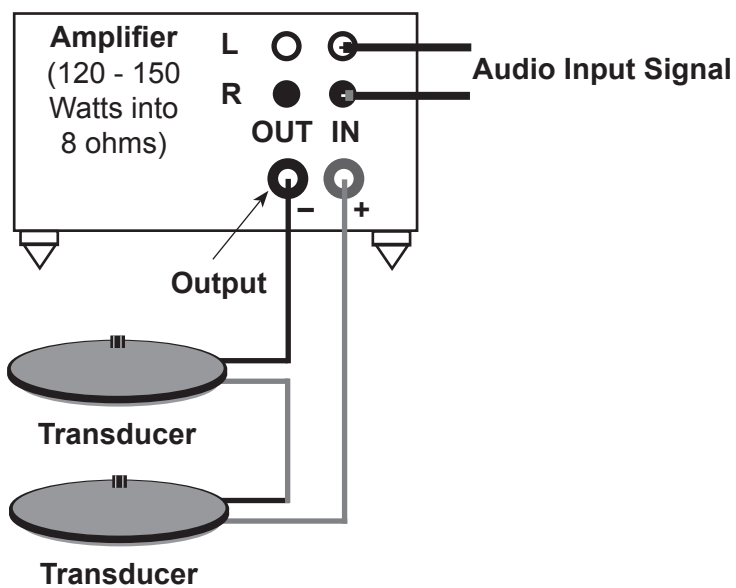



---

# Notes

# Troubleshooting

Symptom	Troubleshooting Question	Remedy
No Tactile Sound	Is the Transducer connected?	Connect the Transducer properly.
	Is the input source connected to the amplifier input?	Connect the input source.
	Is the source outputting a signal?	Connect the source to another amplifier to verify the source is working.
	Is the Gain (Volume) Control turned up?	Slowly turn up the Gain (Volume) Control.
	Is the amplifier properly matched to the Transducer?	Make sure the amplifier is powerful enough and stable with a 4 ohm load.
	Did the Transducer stop working?	Turn the Gain Control down, wait a few minutes, then try again.
Not Enough Tactile Sound	Is the Gain (Volume) Control adjusted properly?	Turn up the source volume and the amplifier's gain (volume) control.
	Is the amplifier properly matched to the Transducer?	Make sure the amplifier is powerful enough and stable with a 4 ohm load.
	Is the Transducer not powerful enough for your application?	Add another Transducer. Use a more powerful Transducer.
Sound Comes and Goes	Did the Transducer output suddenly decrease or did the Transducer stop working?	Turn the Gain Control down, wait a few minutes, then try again.
	Is the amplifier properly matched to the Transducer?	Make sure the amplifier is powerful enough and stable with a 4 ohm load.
I Hear a Rattling or Buzzing Noise	Are all hardware components tightened down?	Tighten all screws and jam nuts.
	Is the Transducer touching anything?	Make sure the Transducer body is not touching any surfaces.
	Is the signal to the Transducer clipping?	Make sure that the signal to the Transducer is not clipped. Try turning down the original signal.
I Hear Noises from my Recliner	Is the recliner "loose"?	Check to make sure that all recliner hardware is tightened. Try wrapping waxed dental floss in the footrest scissor hinges to dampen the vibrations.
	Is the Transducer connected to the surround receiver's center channel?	Connect the Transducer's receiver to either the LFE/Subwoofer signal, or to the LF/RF signals. (Note: Some DVDs contain voices in the LF/RF signals)

# Warranty & Returns

## United States Warranty and Return Policy

### **TST429, TST329, TST239, AW339 Transducer WARRANTY**

Clark Synthesis, Inc. warrants the TST239, TST329, TST429, and AW339 Transducers to be free from defects and workmanship under normal use for a period of two (2) years from date of original purchase. For industrial or commercial use, the warranty period is six (6) months.

This warranty is valid for the original purchaser and is not extended to subsequent owners. Any applicable implied warranties are limited in duration to a period of the express warranty as provided herein beginning with the date of the original purchase at retail, and no warranties, whether expressed or implied, shall apply to this product thereafter. Some states do not allow limitations on implied warranties; therefore these exclusions may not apply to you. This warranty gives you specific legal rights; however, you may have other rights that vary from state to state.

### **WHAT IS NOT COVERED**

This warranty is valid only if the product is used for the purpose for which it was designed. It does not cover the following:

- Damage caused by excessive heat
- Damage through negligence, misuse, accident, or abuse
- Damage caused by incorrectly mounting the Transducer
- Damage due to not using an appropriate amplifier
- Freight damage
- Items repaired by an unauthorized repair facility
- Items damaged due to amplifier clipping and/or distortion
- Items purchased from unauthorized individuals or dealers
- Cost of shipping product to Clark Synthesis, Inc.
- Return shipping on non-defective items

### **RETURN POLICY**

New, unused transducers may be returned within 7 days of the purchase date or the date of receipt. Returns must be in their original packaging, undamaged, and in resellable (new) condition. All hardware and manuals must be included. If the returned transducer does not meet these conditions, you will be charged a 15% restocking fee or have the transducer returned to you at your expense. Shipping charges are not refundable.

### **WHAT TO DO IF YOU NEED WARRANTY OR SERVICE**

Contact Clark Synthesis at 303-797-7500, or email us at [warranty@clarksynthesis.com](mailto:warranty@clarksynthesis.com). You will be given a Return Authorization (RA) number and return instructions.

### **International Warranty and Return Policy**

Contact your international Clark Synthesis dealer or distributor for your country's warranty policies.

full  
contact  
audio™

© 2009 Clark Synthesis, Inc. All Rights Reserved.

Clark Synthesis, Inc.  
Telephone: 303.797.7500  
Fax: 303.797.7501  
Email: [info@clarksynthesis.com](mailto:info@clarksynthesis.com)  
[www.clarksynthesis.com](http://www.clarksynthesis.com)

11/2009

---

[www.clarksynthesis.com](http://www.clarksynthesis.com)