



tactile sound transducer

Installation Guide



Table of Contents

Introduction	1
Related Products	2
Supplied/Required/Optional Items	3
General Installation Tips	4
<i>Installation...</i>	
Overview	5
Chairs & Couches	7
Traditional Floors & Platforms	8
Laminated I-Beam Floors	9
Wood Decks	10
Wiring & Connections	11
Troubleshooting	13

CAUTION THE TACTILE SOUND TRANSDUCER
CONTAINS AN EXTREMELY

Introduction

Before you drill holes and run wires, take a few moments to review this Installation Guide. Then plan out the steps you'll need to take for your particular application. This will save you time in the end and reduce the possibility of errors and/or damage to the transducer.

Thank you for purchasing a Clark Synthesis™ Tactile Sound™ Transducer, and welcome to the amazing world of Tactile Sound!

For many years, Clark Synthesis has been giving its customers the ability to experience sound in a completely different way. As you know, most of the sound we hear reaches our ears via airborne vibrations, like those produced by loudspeakers. However, there are four additional pathways through which we perceive acoustic energy, all of which fall into the category of tactile sound. These additional pathways include:

- Deep tissue and muscle mass (“Kinesthetic”)
- Skeletal joints (“Haptic”)
- Skin sensation (sense of touch)
- Bone conduction (skull-to-cochlea transmission)

To capitalize on these additional means by which we perceive acoustic energy, Tactile Sound Transducers have been designed to send high-quality audio to the listener by producing vibrations over a full range of tactile and audible frequencies. When attached to a resonant surface, the Transducers supplement ordinary speakers and subwoofers, effectively increasing the proportion of tactile sound. Consequently, you feel the natural percussive impact of sounds, bringing life to sound effects like hard footsteps, door slams, plucked strings, drum beats, and explosive movie effects, all while enjoying greater clarity, depth, and realism.

Additionally, because Transducers increase the perceived “loudness” of the sound you are hearing, you are able to lower the volume on your system to a level that is both safer for your ears and less bothersome to neighbors.

Some of the most common applications for Tactile Sound Transducers include home theaters, listening rooms, outdoor decks, military simulators, theme park attractions, game chairs, professional music, and swimming pools.

In home theaters and listening rooms, our Transducers provide the user with a greater depth of experience when watching movies, listening to music, and playing video games.

For outdoor applications, our AW339-All Weather Transducers mount underneath decks, keeping the audio equipment out-of-sight while transferring audio to the surface of the deck.

Many military and flight simulator companies use our TST329-Gold Transducers to bring a greater sense of realism to training exercises.

Pool enthusiasts use our AC339-Aquasonic™ underwater pool speakers to send full-range audio into the water, providing high-quality underwater music.

As you can see, the uses for our Transducers are many and the experience is amazing! We are glad you chose Clark Synthesis Transducers and we hope your listening experience using our products takes you to new levels of acoustical enjoyment!

The logo for full contact audio™ features the words "full", "contact", and "audio" stacked vertically in a bold, lowercase, sans-serif font. The word "full" is smaller than "contact", which is larger than "audio". A small trademark symbol (TM) is located at the bottom right of the word "audio". The text is contained within a thin, rounded rectangular border.

Troubleshooting

Clark Synthesis, Inc. wants to help make every installation the best it can be because we are proud of our superior technical support. However, before calling us directly to discuss any technical issues, please consult the following troubleshooting information.

Clark Synthesis technical support can be reached by calling 303.797.7500, weekdays from 9am to 5pm, Mountain Standard Time or by emailing us at info@clarksynthesis.com. You can also find additional installation notes at www.clarksynthesis.com.

Want more tactile sound in furniture/platform

- Add isolation feet to your furniture or riser to keep the tactile feel from transferring into the floor.

Not enough volume with multiple Transducers

- Make sure the polarity (the + and – speaker leads) is the same on all Transducers. An improperly-wired Transducer will cancel much of the output of a properly-wired Transducer.

I hear rattles or buzzes

- Make sure the jam nuts and hardware connections are secure and tight.
- Make sure the body of the Transducer and its speaker wire are not in contact with any object or surface.
- Make sure the Tactile Amplifier is not clipping or distorting.
- If you are using an equalizer, cut the bass frequencies starting with the lowest band.

I hear buzzes from my recliner

- Try wrapping waxed dental floss (any flavor!) in the scissor hinges of the footrest to dampen the vibrations.
- Inspect the recliner for other loose metal parts and tighten.

I hear voices coming from my chair!

- Make sure the Tactile Amplifier is connected to the LF/RF outputs of your surround-sound component.

The Transducer has shut down

- The Transducer has an internal early-warning circuit that warns you of too much power or too much distortion. The early warning circuit will automatically reset when the condition has been remedied.
- Lower the volume of the Tactile Amplifier.

The Transducer touches the floor under my chair

- The body of the Transducer should not be in contact with any object or surface.
- Raise the chair's feet to clear enough space for the Transducer.
- Or, if space permits, mount the Transducer fastener side down inside the chair.

Related Products

Isolation Feet:

Adding isolation feet to your home theater furniture or platform improves the tactile experience by reducing energy losses into the floor. Clark Synthesis, Inc. carries three different models of isolation feet, each designed to enhance a variety of tactile applications.



TI-100

TI-200

TI-300

Amplifiers:

Clark Synthesis, Inc. sells amplifiers that work great with Clark Transducers. Some of these amplifiers will drive multiple transducers. Contact Clark Synthesis, Inc. for more information.



Tactile Ready™ Theater Seats

Theater seats bearing the Tactile Ready designation include a convenient mounting point for installing a Clark Synthesis Transducer in an ideal location for transmission of tactile vibrations. Such seats have been tested and certified as Tactile Ready™ by Clark Synthesis, Inc.

SUPPLIED PARTS (ILLUSTRATED BELOW)

- A. (1) Tactile Sound Transducer
- B. (1) Unimount Bracket
- C. (1) 3/8"-16 x 3" Hanger Bolt
- D. (1) 3/8"-16 x 3" Threaded Stud
- E. (1) 3/8"-16 x 1.5" Threaded Stud
- F. (1) 3/8"-16 x 1" Hex Bolt
- G. (4) #12 x 1" Screw
- H. (2) 3/8" Nut
- I. (4) #12 Washer
- J. (4) #12 Lock Washer
- K. (1) 3/8" Washer
- L. (1) 3/8" Lock Washer
- M. (1) T-Nut
- Installation Guide

REQUIRED TOOLS AND MATERIALS

Depending on your application, you will need some or all of these tools and materials for installation:

- #2 Phillips Screwdriver
- (2) 9/16" Open-Ended Wrenches
- Drill
- Saw
- Wire Stripper
- Soldering Gun or Wire Nuts
- Adhesive (construction glue)
- Hardwood (oak, maple, ash, etc., not pine or softwoods) for creating mounting bridges
- Speaker Cable (min. 16 AWG; 12-14 AWG recommended)

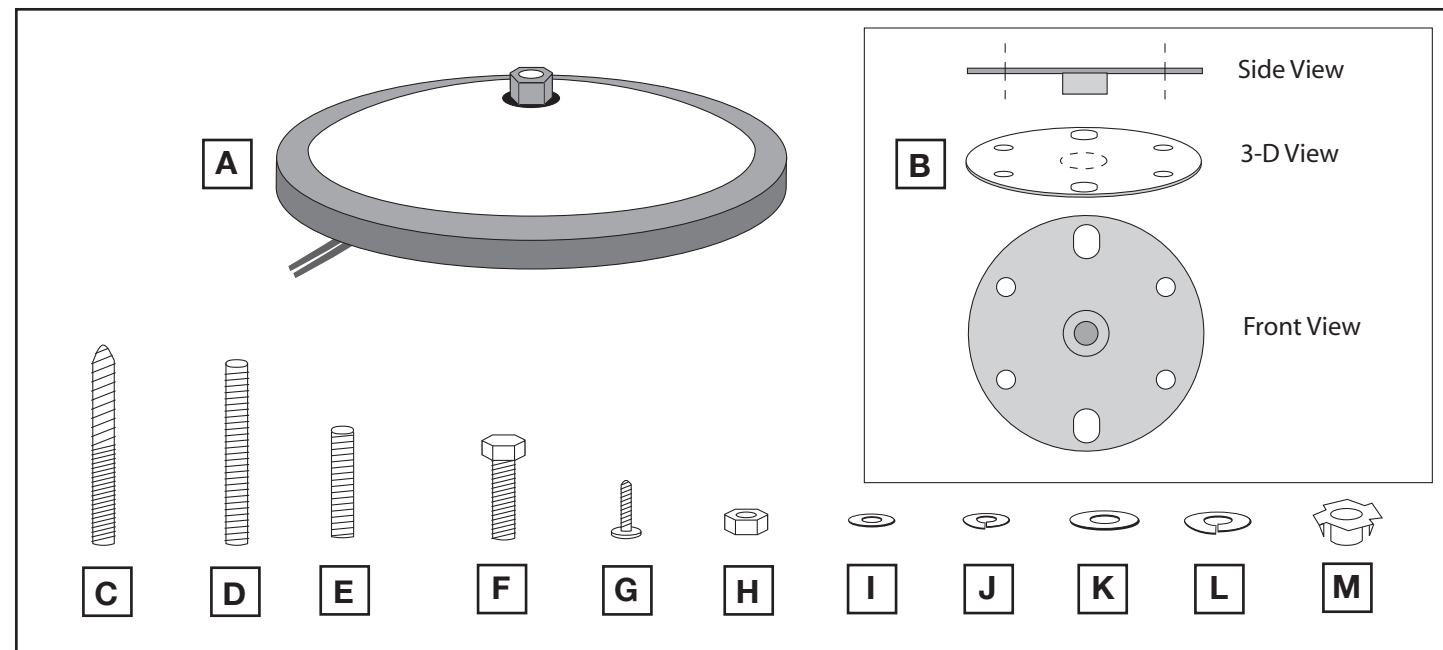

REQUIRED AUDIO COMPONENTS

- Power amplifier

OPTIONAL AUDIO COMPONENTS

- Equalizer to tailor the frequency response of the Transducer(s)

1 Connecting to the FRONT Outputs of a surround-sound processor or receiver

- An optional equalizer allows you to tailor the frequency response of the Transducer.

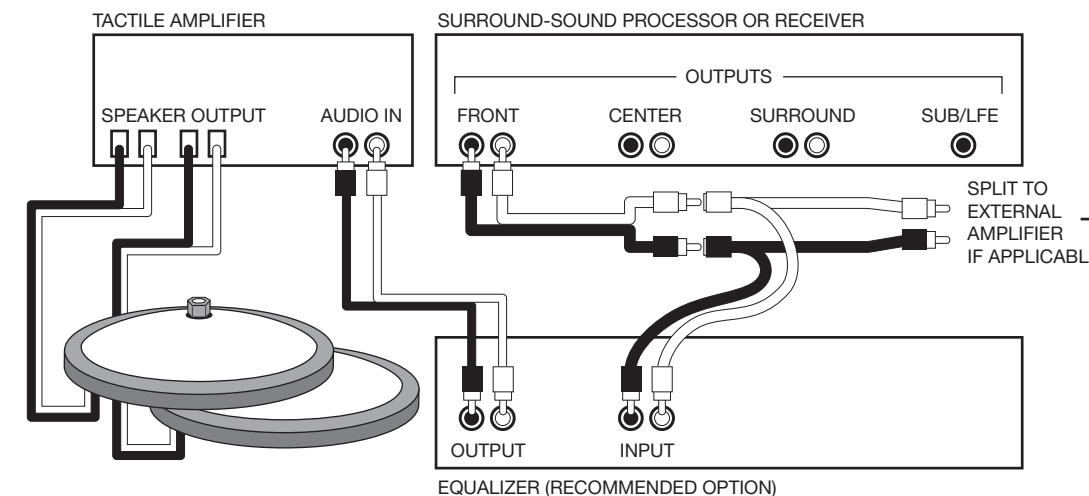

NOTE: If you are using a surround-sound receiver with built-in amplifiers, you **DO NOT** need to split the FRONT output as shown in this diagram.

2 Connecting to the LFE/SUB Output of a surround-sound receiver

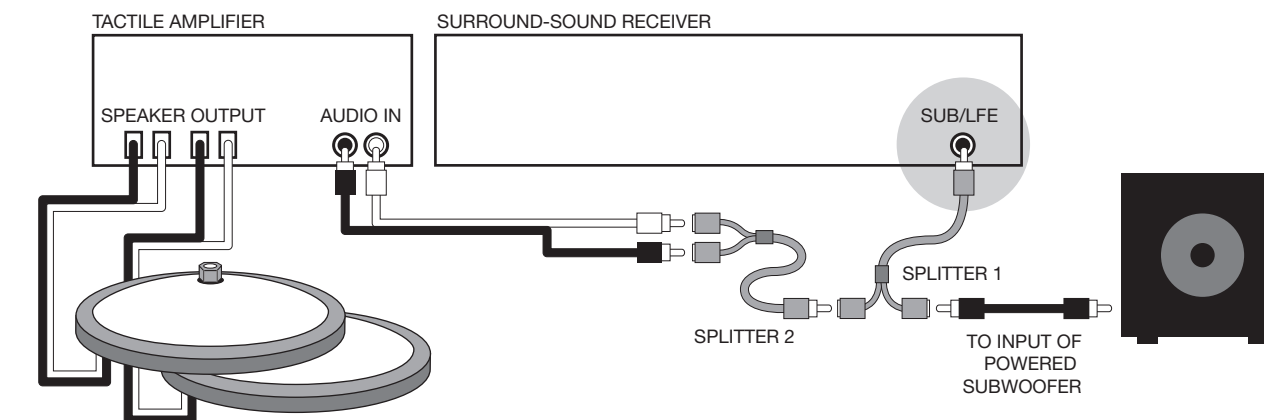

Wiring the Transducer is essentially the same as wiring speakers:

- Use 16AWG or heavier speaker wire.
- Make sure all audio components are OFF before connecting the Transducer.

The diagrams on the following pages show a stereo amplifier powering two Transducers. **If only one Transducer is being used – such as in an individual theater seat – you may use an amplifier that can be bridged to mono. Typical mono and stereo connections are illustrated below. (Refer to your amplifier’s instructions for bridging.) Be careful not to overpower the Transducer (see power ratings on Page 3).**

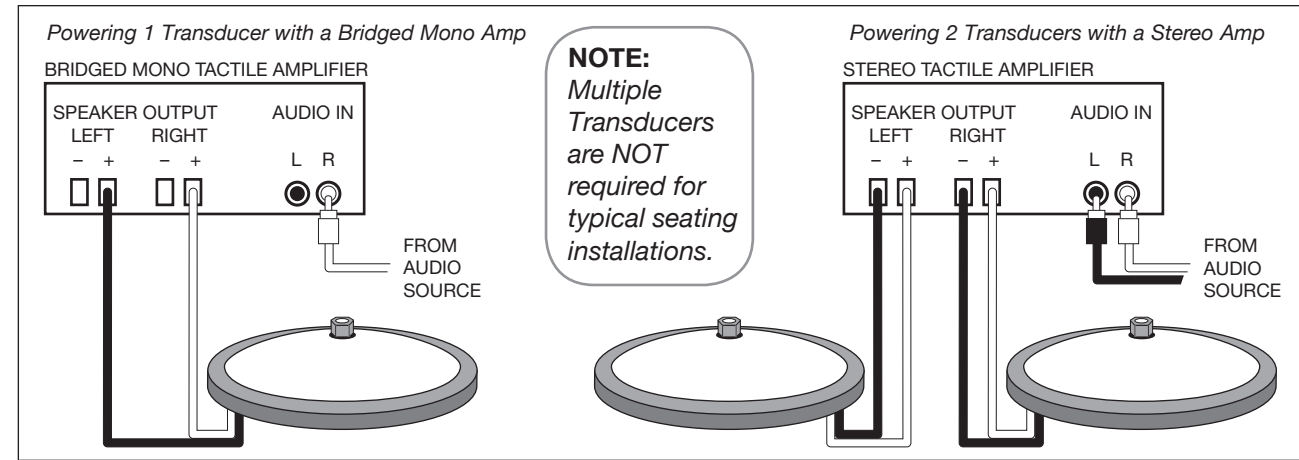

Speaker Cable Considerations

The Transducer includes a permanently attached 3-foot speaker wire. The positive (+) lead is the red wire. Observe this polarity when connecting your amplifier.

You may need to use solder or wire nuts to attach a length of speaker cable to reach the amplifier in your audio system. In any permanent installation, a soldered connection is preferred because wire nuts may vibrate loose.

Speaker cable size (gauge) should be calculated for run length; the longer the run, the larger the cable (the lower the gauge). 12 - 14 AWG is recommended; 16 AWG is minimum.

One of the best materials for carrying tactile sound is wood. In most applications, the Transducer should be centrally located on the structure (chair, floor, riser, deck, etc.) in order to evenly distribute the tactile effect. When two or more Transducers are used on one structure, they should be spaced equidistant from each other and the edges/boundaries of the structure. Mounting to a bridge, joist, or frame member is preferred.

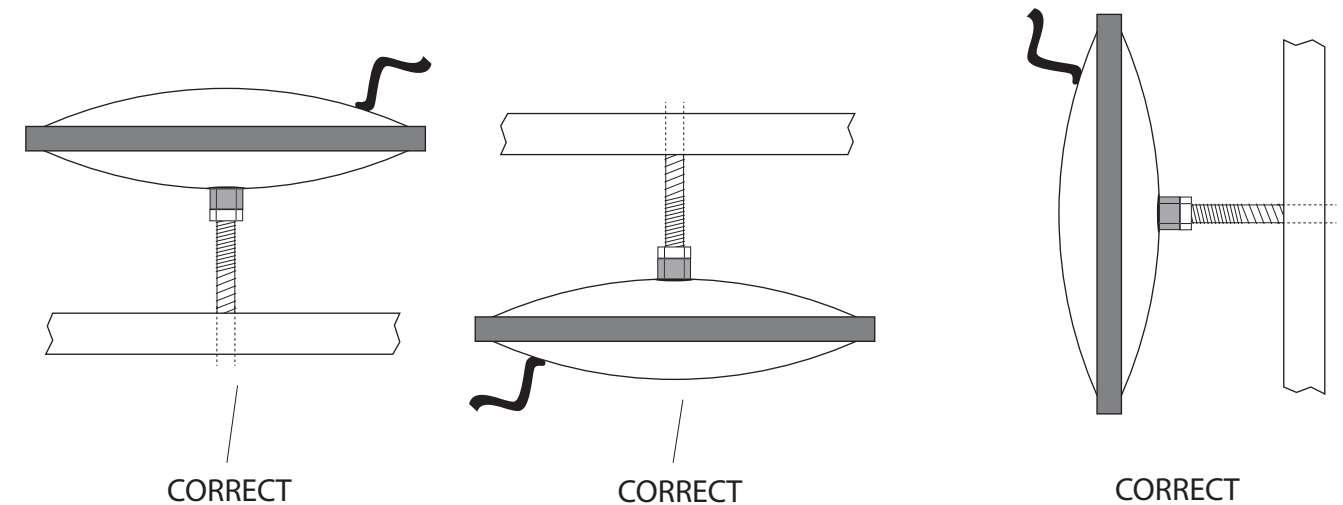
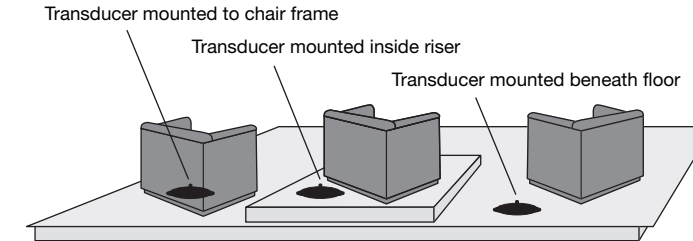

Installation: Overview

Installation Type: Unimount Bracket

Screws into the bottom of the mounting surface.
Requires access only to the bottom of the mounting surface. Requires a flat or nearly flat mounting surface.

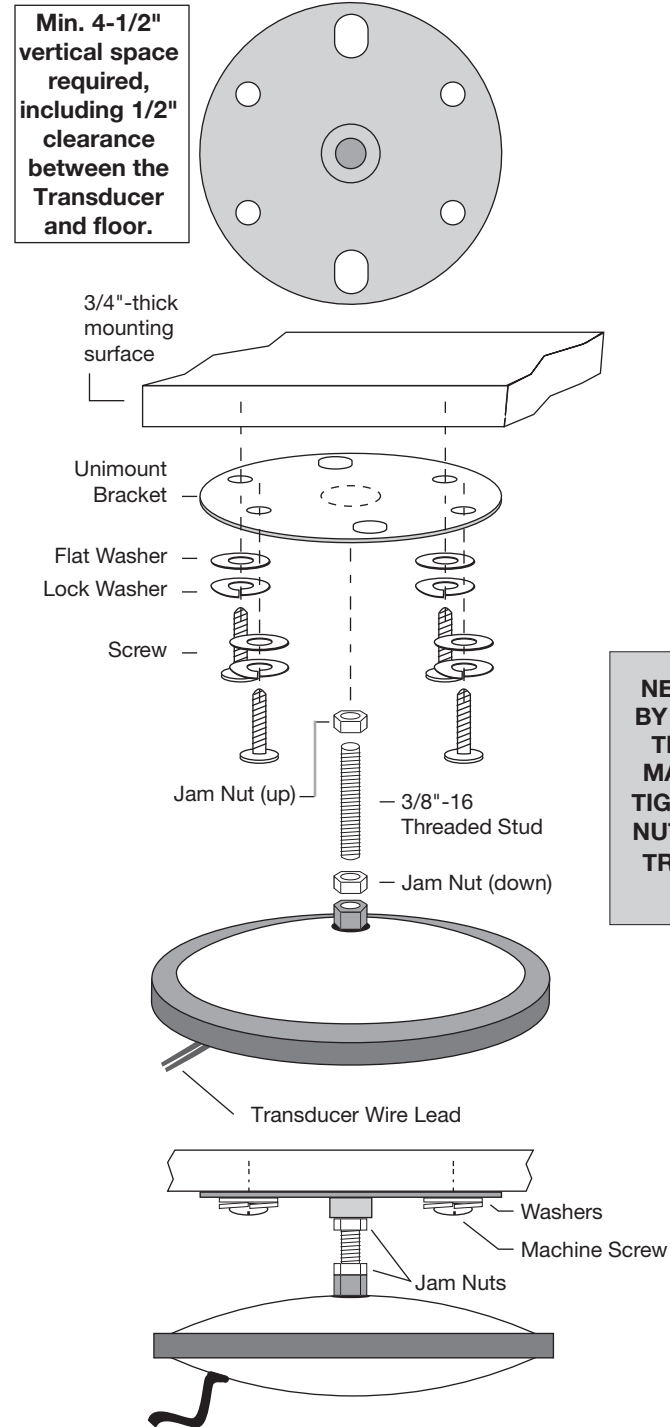

Installation Type: Hanger Bolt

Screws into the bottom of the mounting surface (into a 5/16" drilled hole). Requires access only to the bottom of the mounting surface.

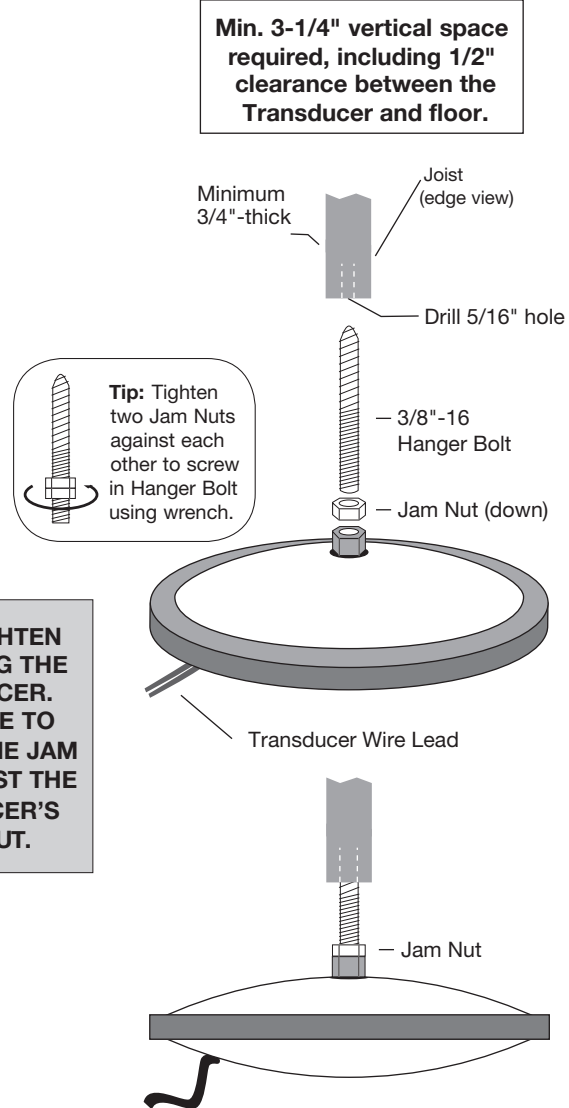

Installation Type: Hanger Bolt

The AW339-All Weather Transducers are recommended for use on outdoor installations, including decks, boat docks, etc.

For decks, we recommend using one (1) All Weather Transducer for every 10 ft. by 10 ft. section of deck. For example, if you have a deck that measures 10 ft. by 30 ft., we would suggest you install three (3) Transducers.

For all installations, regardless of the number of Transducers, we recommend locating the Transducers equidistant from the edges of the deck and/or from each other. This helps create a more uniform distribution of the tactile effect.

The easiest installation method is to use the Hanger Bolt to mount the Transducer(s) to the bottom of the joist(s). Steps for this installation method can be found on Page 8.

Note: If for some reason it is not possible to mount to the joists, use a bridge between joists as you would in a floor installation (see Page 8 for instructions and images for building a bridge).

It is important to make Transducer wire connections as watertight as possible by using electrical tape and molded plastic connectors.

Installation: Wood Decks

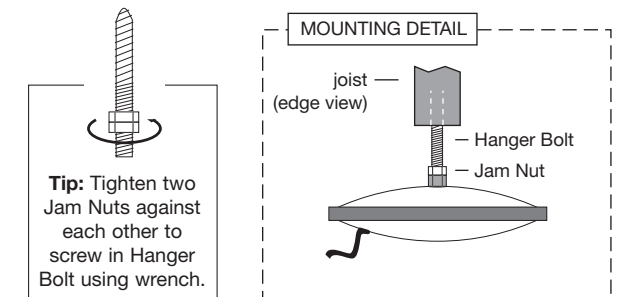
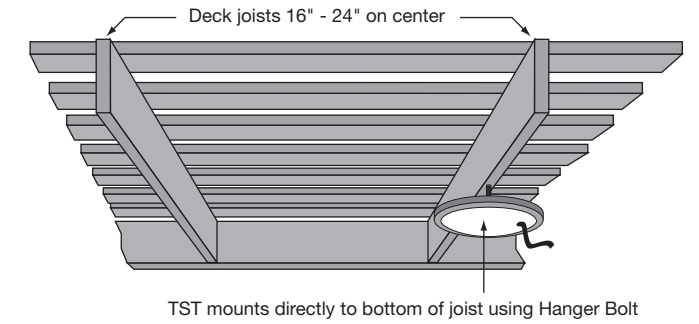

LAMINATED I-BEAM FLOORS

The Transducer will be mounted to a bridge that spans adjacent floor joists and is parallel to the floor.

Steps for installation using the Unimount Bracket

1. Attach the Unimount Bracket to the mounting surface using machine screws with flat washers and lock washers.
2. Screw the a Threaded Stud into the threaded insert on the Unimount Bracket.
3. Spin the two Jam Nuts onto the stud. You will tighten them later.
4. Screw the Transducer onto the Stud until a slight resistance is felt (approx. 5 or 6 turns). When resistance is felt, stop turning.
 - **DO NOT OVERTIGHTEN THE TRANSDUCER!**
5. Tighten one Jam Nut against the Unimount Bracket.
6. Tighten the other Jam Nut against the Transducer's brass nut using two 9/16" wrenches as follows: One wrench firmly grasping the Transducer's brass nut while the second tightens the Jam Nut against it.
 - **NEVER TIGHTEN BY TURNING THE TRANSDUCER – MAKE SURE TO TIGHTEN THE JAM NUT AGAINST THE TRANSDUCER'S BRASS NUT.**
7. Use solder or wire nuts to connect speaker wire to the Transducer's wire leads.
8. Run the speaker wire to your audio system.
9. Connect the Transducer to your audio system (see "Wiring and Connections" later in this guide).

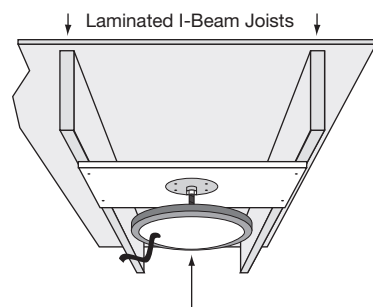

Transducer mounts on 1"x 6" hardwood bridge spanning two joists, using the Unimount Bracket (shown) or the Threaded Stud with T-Nut. Attach the bridge to the bottom face of the joists using adhesive and screws.

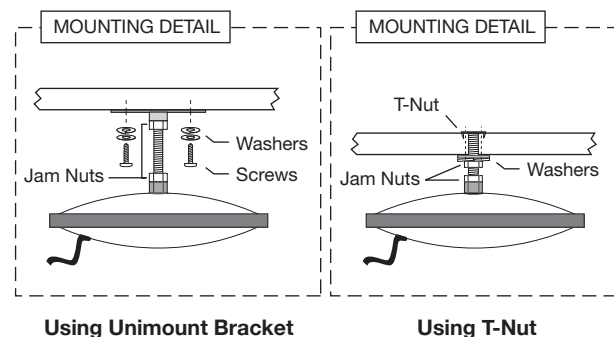

Steps for installation using the T-Nut Method

1. Drill a 7/16" hole in the mounting surface, being careful not to drill through existing materials behind your mounting surface. Press the T-nut into the hole on the side of the mounting surface opposite the Transducer (see diagram).
2. Screw a Threaded Stud completely into the T-Nut.
3. Place the 3/8" flat washer and 3/8" lock washer on the Threaded Stud, then spin the two Jam Nuts onto the stud (flat washer against the mounting surface, lock washer between flat washer and jam nut). You will tighten the jam nuts later.
4. Screw the Transducer onto the Stud until slight resistance is felt (approx. 5 or 6 turns). When resistance is felt, stop turning.
 - **DO NOT OVERTIGHTEN THE TRANSDUCER!**
5. Tighten one Jam Nut against the lock washer, flat washer, and mounting surface.
6. Follow steps 6 through 9 under "Steps for installation using the Unimount Bracket" (as shown above).

Installation Type: T-Nut

Requires initial access to the top of the material to insert the T-Nut, which installs near flush to the surface. (Drill a 7/16" hole for the T-Nut.)

(See diagram in "Installation: Chairs and Couches").

Min. 3-1/2" vertical space required, including 1/2" clearance between the Transducer and floor.

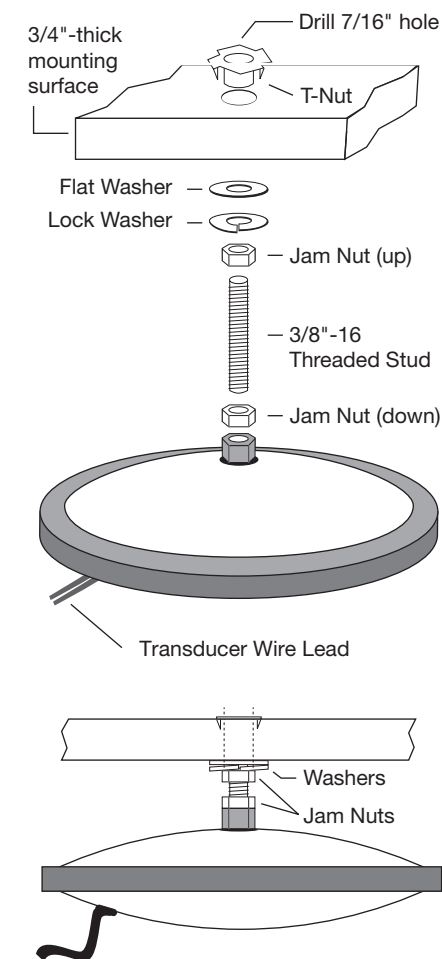

NEVER TIGHTEN BY TURNING THE TRANSDUCER. MAKE SURE TO TIGHTEN THE JAM NUT AGAINST THE TRANSDUCER'S BRASS NUT.

Installation Type: Hex Bolt

For use with metal or some other high-tensile mounting surfaces no thicker than 1/4". Requires access to the top of the mounting surface both to install the bolt and to tighten it.

Min. 3-1/4" vertical space required, including 1/2" clearance between the Transducer and floor.

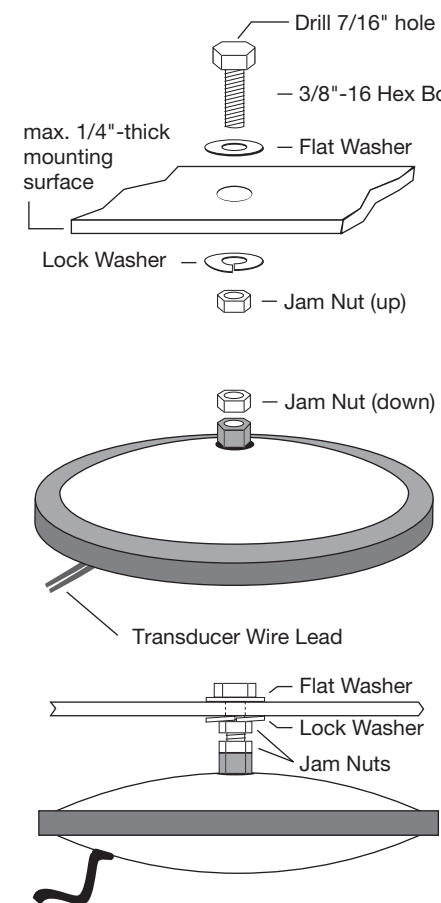

Installation: Chairs & Couches

Installation Type: Unimount Bracket or T-Nut

NOTE: If your chair or couch cannot accommodate a Transducer, consider purchasing or constructing a platform (see "Platforms" on Page 8).

As a general rule, most chairs and couches have an underlying wooden frame. The Transducer can be mounted directly to a frame member or to a hard wood bridge (see diagram) that is rigidly secured to the chair's/couch's base. The bridge should be at least 3/4" thick and cut to span two frame members or connect two sides of a box frame. The more centrally located the frame member or bridge is on the overall structure, the better the distribution of tactile sound.

CAUTION: When used in recliners, make sure that the Transducer and its wire do not interfere with the recliner's mechanical elements. Also, a minimum clearance from floor to mounting surface for these types of installs is 4-1/2 inches for the Unimount Bracket and 3-1/2 inches for the T-Nut.

Steps for installation using the Unimount Bracket

1. Attach the Unimount Bracket to the mounting surface using machine screws with flat washers and lock washers.
2. Screw a Threaded Stud into the threaded insert on the Unimount Bracket.
3. Spin the two Jam Nuts onto the stud. You will tighten them later.
4. Screw the Transducer onto the Stud until slight resistance is felt (approx. 5 or 6 turns). When resistance is felt, stop turning.
 - **DO NOT OVERTIGHTEN THE TRANSDUCER!**
5. Tighten one Jam Nut against the threaded insert of the Unimount Bracket.
6. Tighten the other Jam Nut against the Transducer's brass nut using two 9/16" wrenches as follows: One wrench firmly grasping the Transducer's brass nut while the second tightens the Jam Nut against it.
 - **NEVER TIGHTEN BY TURNING THE TRANSDUCER – MAKE SURE TO TIGHTEN THE JAM NUT AGAINST THE TRANSDUCER'S BRASS NUT.**
7. Use solder or wire nuts to connect the necessary length of speaker wire to the Transducer's wire leads.
8. Run the speaker wire to your audio system.
9. Connect the Transducer to your audio system (see "Wiring and Connections" later in this guide).

Steps for installation using the T-Nut Method

1. Drill a 7/16" hole in the mounting surface, being careful not to drill through existing springs, padding, strapping, etc. Press the T-nut into the hole on the side of the mounting surface opposite the Transducer (see diagram).
2. Screw a Threaded Stud completely into the T-Nut.
3. Place the 3/8" flat washer and 3/8" lock washer on the Threaded Stud, then spin the two Jam Nuts onto the stud (flat washer against the mounting surface, lock washer between flat washer and jam nut). You will tighten the jam nuts later.
4. Screw the Transducer onto the Stud until slight resistance is felt (approx. 5 or 6 turns). When resistance is felt, stop turning.
 - **DO NOT OVERTIGHTEN THE TRANSDUCER!**
5. Tighten one Jam Nut against the lock washer, flat washer, and mounting surface.
6. Follow steps 6 through 9 under "Steps for installation using the Unimount Bracket" (as shown above).

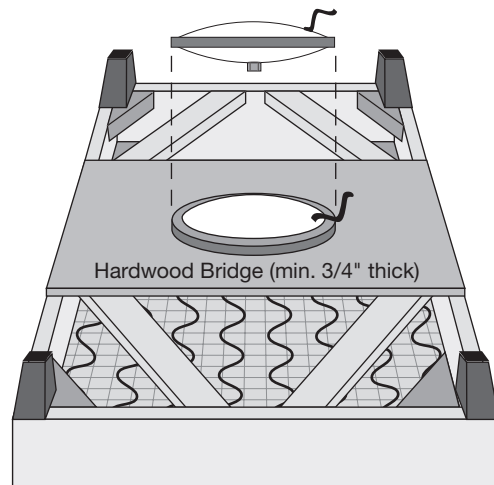

Transducer mounts on hardwood bridge attached to chair frame, or to a centrally-located frame member, if present. Bridge should be min. 3/4" thick and 6" – 8" wide.

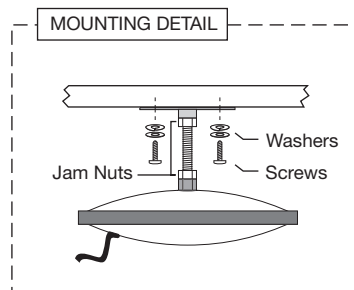

Using Unimount Bracket

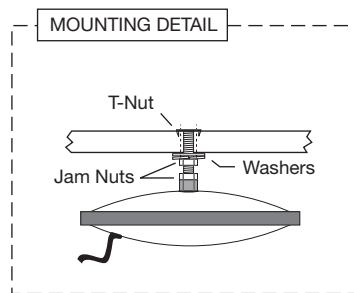

Using T-Nut

Installation: Traditional Floors & Platforms

Installation Type: Hanger Bolt

TRADITIONAL FLOORS

If you want to use Transducers under the floor to supplement a music system, then you should seek an evenly distributed effect. Transducers may be mounted under a floor by attaching a bridge connected between adjacent floor joists.

If your goal is to activate the area of the floor directly beneath a chair, then attach the Transducer to the closest joist underneath the chair.

Note: Carpeting and padding may reduce the tactile effect.

PLATFORMS

Recommendation: Clark Synthesis recommends using only TST429-Platinum Transducers for platforms. Use of (1) TST429-Platinum for every 4 ft. by 8 ft. section of platform is suggested.

Platforms are a great alternative to mounting a Transducer directly to a chair. This method is especially practical in home theaters with multiple rows of seating where back rows are elevated on a riser. An activated platform will deliver tactile sensations to your feet as well as the rest of your body via the chair.

Whether constructing a new platform or fitting Transducers onto an existing platform, it is best to space the Transducers equidistant from each other and the edges of the platform. If using only one Transducer, locate it in the center of the platform.

To minimize energy loss into the floor, use Isolation Feet between the platform and the floor (see Page 2).

NOTE: Clark Synthesis does not recommend using MDF (medium-density fiberboard) in a platform.

Steps for installation using the Hanger Bolt

1. Drill a 5/16" hole in the wood mounting surface and screw in the pointed end of the Hanger Bolt until it is secure.
2. Spin one Jam Nut onto the Hanger Bolt approximately 1".
3. Screw the Transducer onto the Hanger Bolt until slight resistance is felt (approx. 5 or 6 turns). When slight resistance is felt, stop turning.
 - **DO NOT OVERTIGHTEN THE TRANSDUCER!**
4. Tighten the Jam Nut against the Transducer's brass nut using two 9/16" wrenches as follows: One wrench firmly grasping the Transducer's brass fastener while the second tightens the Jam Nut against it.
 - **NEVER TIGHTEN BY TURNING THE TRANSDUCER – MAKE SURE TO TIGHTEN THE JAM NUT AGAINST THE TRANSDUCER'S BRASS NUT.**
5. Use solder or wire nuts to connect speaker wire to the Transducer's wire leads.
6. Run the speaker wire to your audio system.
7. Connect the Transducer to your audio system (see "Wiring and Connections" later in this guide).

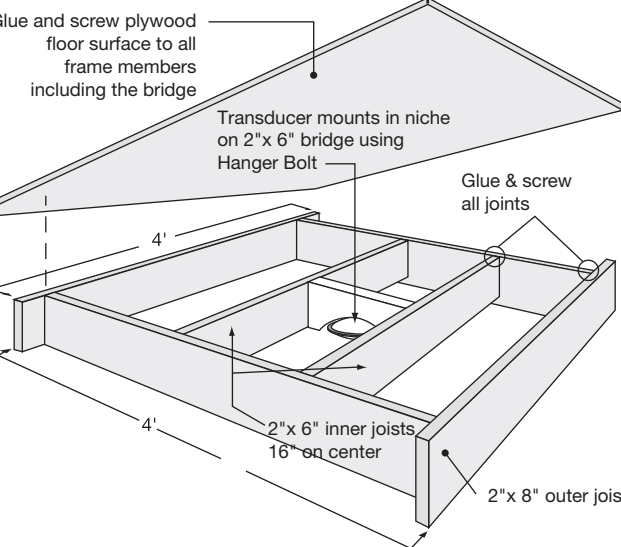
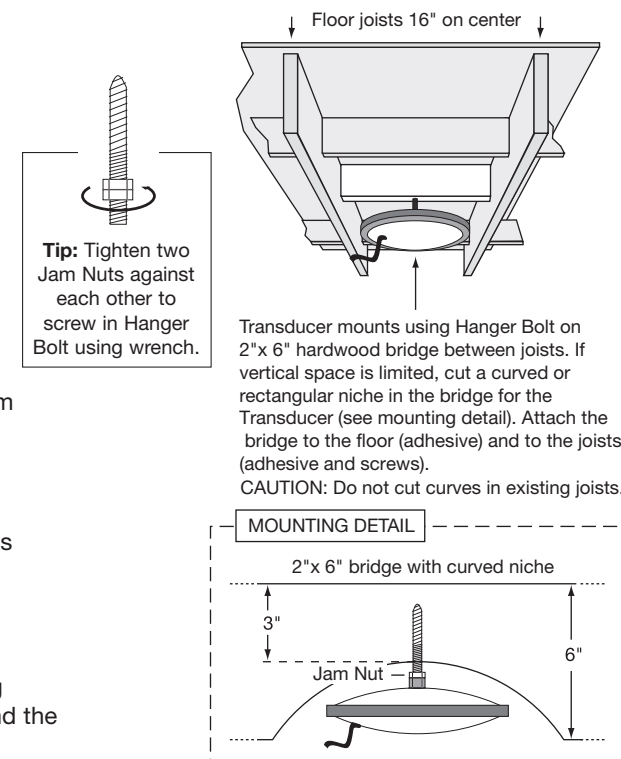

Constructing a platform for optimum Transducer Performance. Use 2" x 8" outside joists and 2" x 6" inside joists. The 2" difference in joist height suspends the center of that platform above the actual floor, improving distribution of the tactile vibrations. Use interior-grade plywood for the platform surface. We highly recommend using adhesive and screws instead of nails. Loose fitting joints can cause unwanted vibrations or buzzing noises, particularly between the joists and the platform surface. Shown is a 4'x4' platform, but you can make any size as long as the joists are spaced 24" or 16" on center to provide sufficient rigidity for tactile wave transmission.